



PITBULL MODELS T2C & T2S TRANSFER AND SELF-PRIMING PUMPS

The model T2C (steel) and T2S (316SS) are transfer pumps designed for dry-piped applications, and can be either gravity fed or configured for suction lift applications. The T2's are suited for heavy/constant use in difficult fluid applications. Able to pass 2" solids along with abrasives, stringy materials, slurries and corrosives, the PITBULL's simple, seal-less design is the solution to many high maintenance applications.

Typical applications includes tank car unloading, tank sludge, ash, scale, sand and other abrasive slurries, vacuum drum filters, clarifier underflow, trash and solids.

Each pump comes complete with the AP200 pneumatic control panel and 15' of connecting airlines. Pumps can also be equipped with a self-priming option for suction lifts up to 15' @ 1.0 sg; (see reverse side for suction lift performance details).

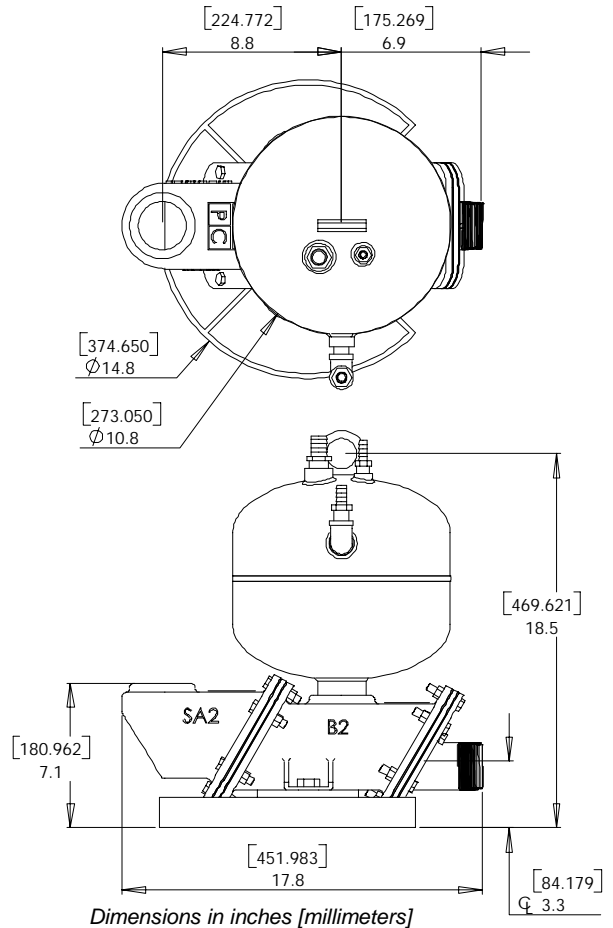

SPECIFICATIONS

- } Weight: 58 lbs/24 kg
- } Piping: 2" NPT
- } Control panel: AP200 (pneumatic)
- } Volume: 2.6 gal/9.8 liters
- } Maximum discharge head: 100 psi/6.9 Bar
- } Maximum solid: 2 inch/51mm diameter
- } Lowest flooded operating level
 - 12 inches/305mm (above pump base)
- } Maximum suction lift (optional)
 - 15 feet/4.6m (@ 1.0 sg; see reverse side for details)

REQUIREMENTS

- } Compressed air or dry gas, >40 psi/2.8 Bar
- } 1/2" NPT air supply inlet

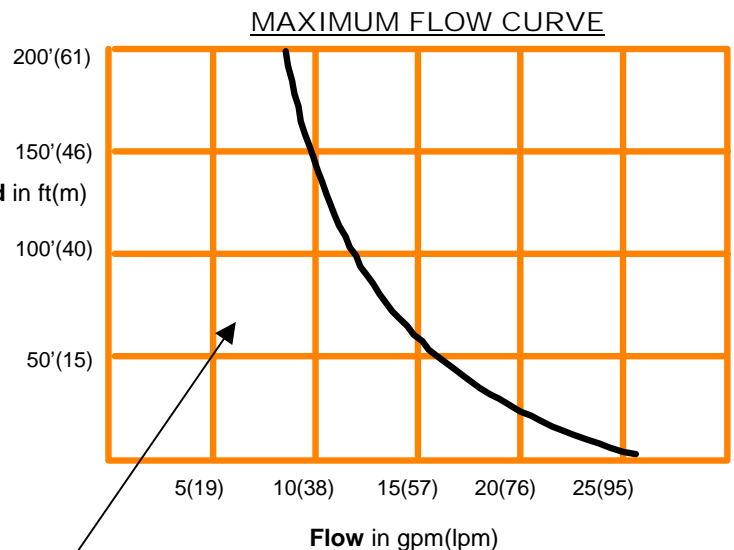

Pump can operate anywhere left of the curve.

Model and options selection:

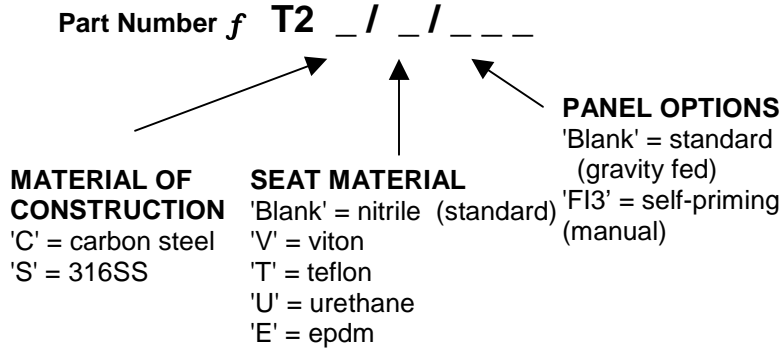

Standard units:

- #T2C = a steel submersible pump with steel checks and nitrile seats.
- #T2S = a 316SS submersible pump with 316SS checks and nitrile seats.

Optional examples:

- #T2C/U/FI3 = a steel submersible pump with urethane seats and self-priming option.
- #T2S/V = a 316SS submersible pump with viton seats.

A complete pump contains: pump, inlet and discharge check valves, an AP200 pneumatic control panel with 15' of airlines.

Description of options:

'FI3' self priming. This is an air powered, vacuum generator mounted to the exhaust valve of the control panel. It is operated by a manual ball valve: 'open' generates full suction lift, 'closed' the pump runs as a standard, gravity fed unit.

Valve seat selection:

- Nitrile - good all-purpose elastomer. Medium chemical, oil and solvent resistance, good strength, use to 170°F.
- Viton - excellent resistance to oxidizers and solvents. Medium strength, use to 250°F.
- Teflon - best chemical resistance of all. Inert to acids, bases and solvents. Lower cycle life, non-elastomeric, use to 300°F.
- Urethane - best resistance to abrasion. Toughest of the elastomers, with mild chemical resistance, use to 150°F.
- EPDM - good heat and acid/base resistance. Tougher than viton but poor solvent resistance, use to 300°F.

SELF-PRIMING NOTES

Flow rates are based upon 4' or less of suction lift. Deduct approximately 10% from the rated flow for each 1.5' of suction lift greater than 4'.
On/Off of the self-priming is controlled by a ball valve. Air solenoid valves controlled by level controls or other inputs can be used.

SELF-PRIMING AIR USAGE

The air consumption chart is based upon gravity fed conditions. Using the self-priming option will increase air consumption 8 - 15 SCFM depending on the suction lift and flow required. Minimum pressure required to create suction lift is 50 psi, with maximum performance at 80 psi.

AIR CONSUMPTION in SCFM

Head Flow	10 ft	20 ft	40 ft	60 ft	80 ft	100 ft	140 ft	180 ft	220 ft
10 gpm	2	2.4	3.2	4.1	4.9	5.8	7.5	9.3	11
20 gpm	3.8	4.7	6.4	8.1	9.9	11.6	15.1	18.5	22
30 gpm	5.7	7	9.6	12.2	14.8	17.4	22.6	27.8	33
40 gpm	7.6	9.4	12.8	16.3	19.7	23.2	30.1	37.1	44
60 gpm	11.4	14	19.2	24.4	29.6	34.8	45.2	55.6	66
80 gpm	15.2	18.7	25.6	32.6	39.5	46.4	60.3	74.1	88
100 gpm	19	23.4	32	40.7	49.4	58	75.3	92.7	110
140 gpm	26.6	32.7	44.8	57	69.1	81.2	105.5	129.7	154

Example: 30 gpm @ 20 ft TDH requires 7 SCFM

COMMONLY ASKED INSTALLATION/APPLICATION QUESTIONS

How is the pump controlled?

On-Off should be controlled by opening or closing the liquid supply or vent path. Without liquid the pump will not cycle (do not cut off the air supply - the pump will fill and not be able to pressurize).

Can the flow rate be controlled?

Yes, three different ways. 1) throttle the inflow to slow the cycle rate, 2) throttle the exhaust to slow the fill rate, 3) adjust the air pressure to control the discharge flow rate.

Can the piping be reduced?

Smaller piping causes higher head and velocity, and the pump may pass things the piping can't. Try to avoid dropping more than one pipe size.

Should isolation valves be used before and after the pump?

Absolutely.

How does the self priming work?

By sucking air out of the pump, much like a vac truck, or vacuum cleaner. CIPC uses a venturi principle to create the vacuum, without any moving parts.