

# PITBULL MODELS S4C & S4S

## 4" SUBMERSIBLE PUMPS

The models S4C (steel) and S4S (316SS) are capable of pumping a wide variety of debris, solids and sludges, solvents and chemicals. Outfitted with CIPC full port check valves, these 4" units can pump a 3.75" diameter solid at low to medium flows and high heads. This makes the S4's capable of handling some truly large, difficult solids. Whether long and fibrous or large and abrasive, solids easily pass through the S4's large diameter flow path. The AP200 pneumatic panel is supplied with the pump and is fully automatic.

Applications for these PITBULL® pumps are almost limitless. Wood yard sumps, coal handling sumps, bottom ash and clinker sumps, machining chips, packing plant waste, poultry offals, feathers, raw sewage, battery sludge, tank farm sumps, slop oils, lime slurry, sand/silt; the list of excellent applications is extensive.

*They are also available with a flow inducement option to help pull in bridging solids or viscous mixtures (great for cleaning sumps with heavy, settled solids).*

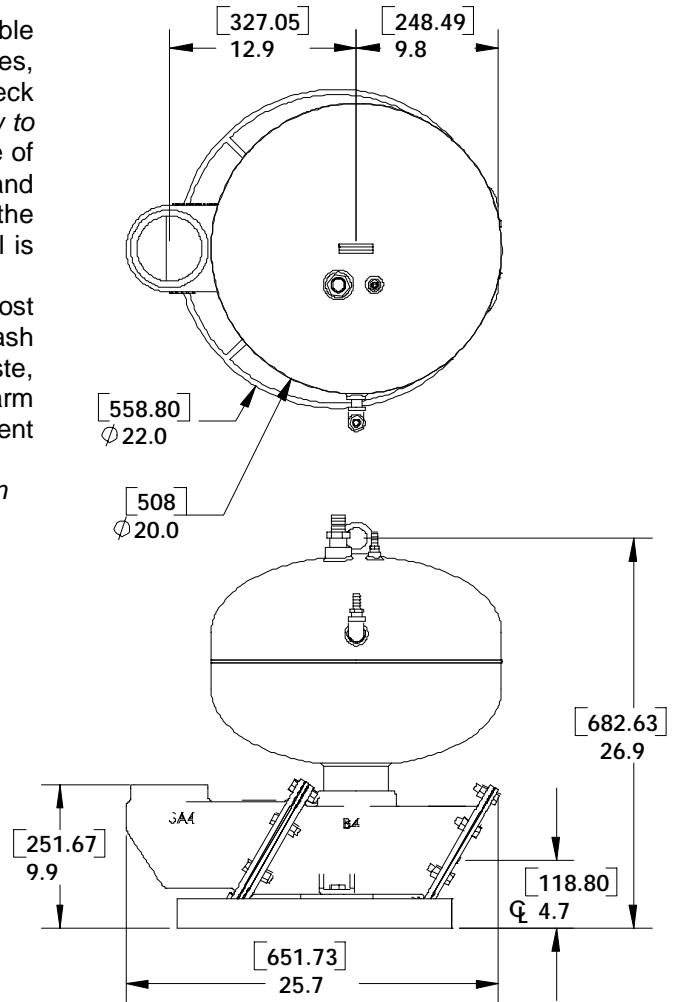

Dimensions in inches [millimeters]

### SPECIFICATIONS

- } Weight: 148 lbs/67kg
- } Piping: 4 inch NPT
- } Control panel: AP200 (all-pneumatic)
- } Volume: 13.5 gal/51.1 liters
- } Maximum discharge head: 100 psi/6.9 Bar
- } Maximum solid: 3.75 inch/95 mm diameter
- } Lowest submerged operating level
  - 20 inches/51 mm (liquid depth)
- } Maximum suction force (optional)
  - 16 inches/406 mm Hg

### REQUIREMENTS

- } Compressed air or dry gas, >40 psi/2.8 Bar
- } 1/2" NPT air supply inlet

### MAXIMUM FLOW CURVE

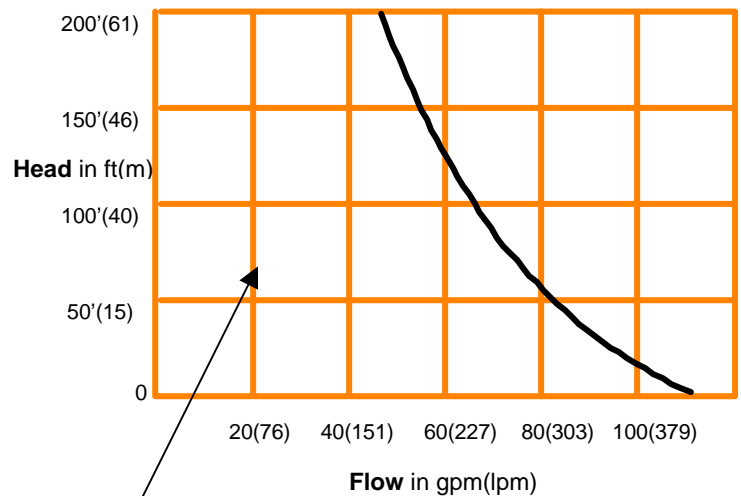

Pump can operate anywhere left of the curve.

Model and options selection:

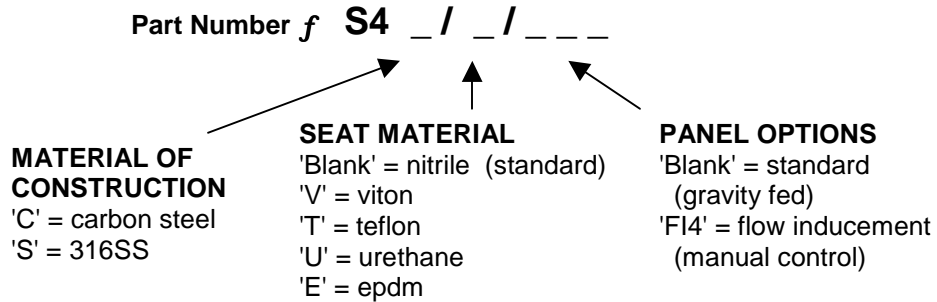

**Standard units:**

- #S4C = a steel submersible pump with steel checks and nitrile seats.
- #S4S = a 316SS submersible pump with 316SS checks and nitrile seats.

**Optional examples:**

- #S4C/U/FI4 = a steel submersible pump with urethane seats and flow inducement option.
- #S4S/V = a 316SS submersible pump with viton seats.

A complete pump contains: pump, inlet and discharge check valves, an AP200 control panel and 15' of nitrile/polyester braided airlines (3).  
 Optional panels are EP250 electropneumatic and AP250 all-pneumatic; both are designed for low level, vacuum filled (continuous) operation.

**Description of options:**

'FI4' flow inducement . This is an air powered, vacuum generator and a relief check valve, mounted to the exhaust valve of the control panel. It is operated by a manual ball valve: 'open' generates full suction force; with the valve 'closed' the pump runs as a standard, gravity fed unit

**Valve seat selection:**

- Nitrile - good all-purpose elastomer. Medium chemical, oil and solvent resistance, good strength, use to 170°F.
- Viton - excellent resistance to oxidizers and solvents. Medium strength, use to 250°F.
- Teflon - best chemical resistance of all. Inert to acids, bases and solvents. Lower cycle life, non-elastomeric, use to 300°F.
- Urethane - best resistance to abrasion. Toughest of the elastomers, with mild chemical resistance, use to 150°F.
- EPDM - good heat and acid/base resistance. Tougher than viton but poor solvent resistance, use to 300°F.

**AIR CONSUMPTION in SCFM**

Head Flow	10 ft	20 ft	40 ft	60 ft	80 ft	100 ft	140 ft	180 ft	220 ft
10 gpm	2	2.4	3.2	4.1	4.9	5.8	7.5	9.3	11
20 gpm	3.8	4.7	6.4	8.1	9.9	11.6	15.1	18.5	22
30 gpm	5.7	7	9.6	12.2	14.8	17.4	22.6	27.8	33
40 gpm	7.6	9.4	12.8	16.3	19.7	23.2	30.1	37.1	44
60 gpm	11.4	14	19.2	24.4	29.6	34.8	45.2	55.6	66
80 gpm	15.2	18.7	25.6	32.6	39.5	46.4	60.3	74.1	88
100 gpm	19	23.4	32	40.7	49.4	58	75.3	92.7	110
140 gpm	26.6	32.7	44.8	57	69.1	81.2	105.5	129.7	154

Example: 80 gpm @ 20 ft TDH requires 18.7 SCFM

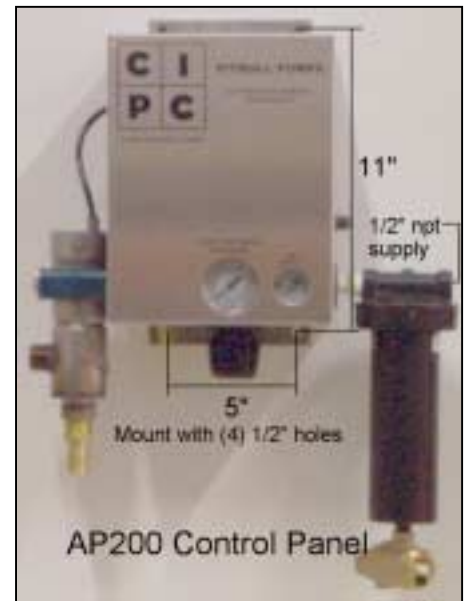

**COMMONLY ASKED INSTALLATION/APPLICATION QUESTIONS**

*How much air will it actually use?*

The Pitbull ® matches your incoming flow rate. So when the inflow drops to half, the air consumption is cut in half too. Actual air consumption is usually much less than shown unless inflow is constant.

*Where is the control panel mounted?*

Place within the 15' radius of the airlines, above the pump. Up to 20' extra lines can be ordered (consult CIPC if more is required).

*Can the airlines be hard-piped?*

Yes they can, but the ID's of our standard lines must be matched.

*Can the piping be reduced?*

Smaller piping causes higher head and velocity, and the pump may pass things the piping can't. Try to avoid dropping more than one pipe size.