

PITBULL® MODEL S3V 3" SUBMERSIBLE PUMP

The model S3V is a nonmetallic submersible pump designed to operate reliably in difficult sump environments. It is fully automatic and can be run with either the AP200 (all-pneumatic) or EP250 (electro-pneumatic) control panel.

Solids capacity is 2" in diameter, which allows them to pump significant levels of debris/solids in highly corrosive conditions. The S3V can pump a very wide range of chemicals at heads up to 100 psi.

The S3V handles all manner of chemical sumps with acids ranging from hydrochloric, sulfuric, nitric, and phosphoric to sodium hydroxide and sodium hypochlorite. In addition to in-plant sumps, areas like tank car unloading, tank farms, and secondary containment dikes, hazardous and remote locations are among the many types of service suitable for these units.

When equipped with the flow inducement option a S3V can pull sump levels down to almost sump floor level, minimizing the standing liquid volume.

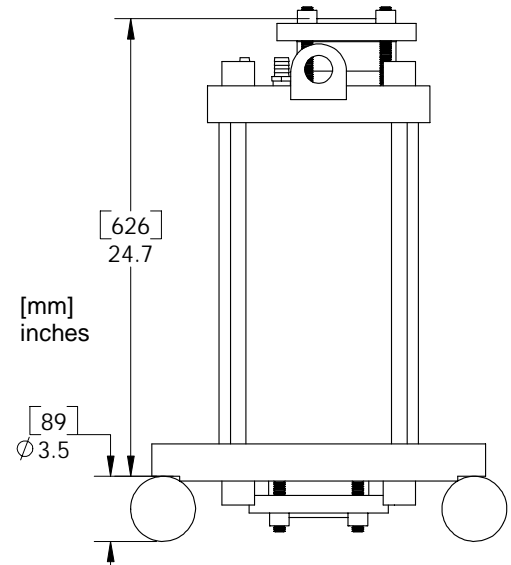
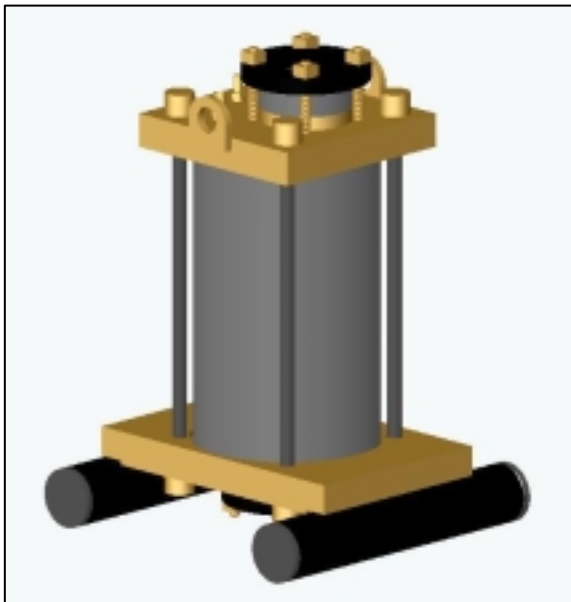
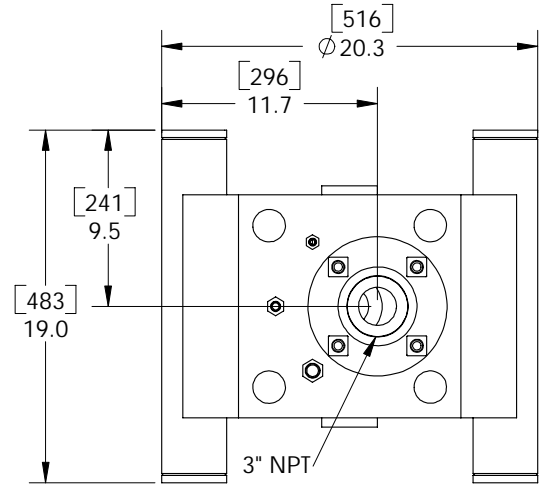

SPECIFICATIONS

- Inlet/Outlet: 3" NPT flange adapters
- Weight: 80 lbs
- Operating Levels:
 - Gravity fed- 18"
 - Flow induced- 6" (or lower with drop pipe)
- Control Panels: AP200 or EP250
- Materials:
 - Chamber- vinyl ester composite
 - Base/check valves- polypropylene
 - Fasteners- vinyl ester composite
 - Maximum solid: 2"
 - Maximum head: 100 psi
 - Maximum temperature: 150F

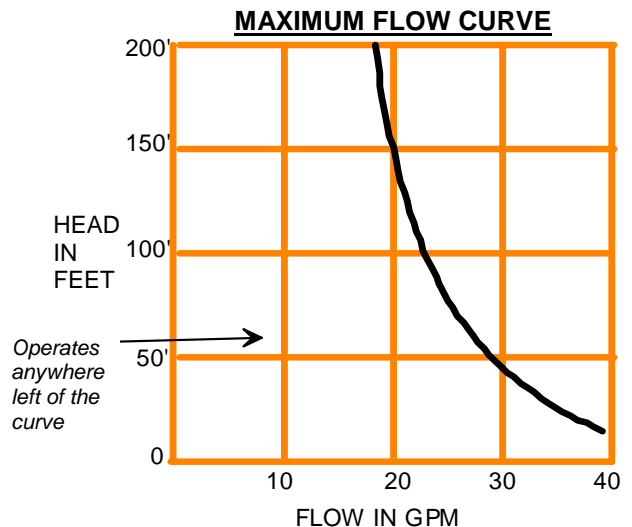

See reverse side for air consumption, ordering information and CIPC BULLETIN # S3V06

Model and options selection:

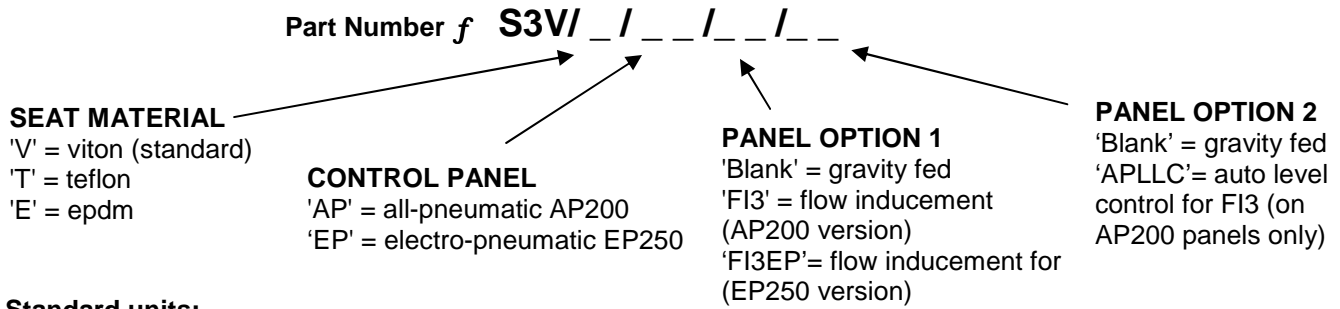

Standard units:

#S3V/V/AP = a vinyl ester submersible pump with polypropylene checks, viton seats and AP200 panel.
 #S3V/V/EP = a vinyl ester submersible pump with polypropylene checks, viton seats and EP250 panel.

Optional examples:

#S3V/V/AP/FI3 = a vinyl ester submersible pump with polypropylene checks, viton seats and AP200 panel with manual flow inducement option.
 #S3V/E/EP/FI3EP = a vinyl ester submersible pump with polypropylene checks, epdm seats and EP250 panel with liquid level controlled flow inducement..

A complete pump contains: pump, inlet and discharge check valves, a control panel and 15' of nitrile/polyester braided airlines (3).

Description of options:

'FI3' flow inducement. This is an air powered, vacuum generator mounted to the exhaust valve of the control panel. It is operated by a manual ball valve: 'open' generates full suction force; with the valve 'closed' the pump runs as a standard, gravity fed unit. Sized for 2" and 3" pumps
'FI3EP' Same as above with additional level-controlled air valve to supply vacuum generator for fully automatic, flow induced operation using the EP250 panel configuration.
'APLLC' Automatic level control, all-pneumatic, for all AP200 flow inducers.

Valve seat selection:

Viton - excellent resistance to oxidizers and solvents. Medium strength, use to 250°F.
Teflon - best chemical resistance of all. Inert to acids, bases and solvents. Lower cycle life, non-elastomeric, use to 300°F.
EPDM - good heat and acid/base resistance. Tougher than viton but poor solvent resistance, use to 300°F.

AIR CONSUMPTION in SCFM

Head Flow	10 ft	20 ft	40 ft	60 ft	80 ft	100 ft	140 ft	180 ft	220 ft
10 gpm	2	2.4	3.2	4.1	4.9	5.8	7.5	9.3	11
20 gpm	3.8	4.7	6.4	8.1	9.9	11.6	15.1	18.5	22
30 gpm	5.7	7	9.6	12.2	14.8	17.4	22.6	27.8	33
40 gpm	7.6	9.4	12.8	16.3	19.7	23.2	30.1	37.1	44
60 gpm	11.4	14	19.2	24.4	29.6	34.8	45.2	55.6	66
80 gpm	15.2	18.7	25.6	32.6	39.5	46.4	60.3	74.1	88
100 gpm	19	23.4	32	40.7	49.4	58	75.3	92.7	110
140 gpm	26.6	32.7	44.8	57	69.1	81.2	105.5	129.7	154

Example: 20 gpm @ 20 ft TDH requires 4.7 SCFM

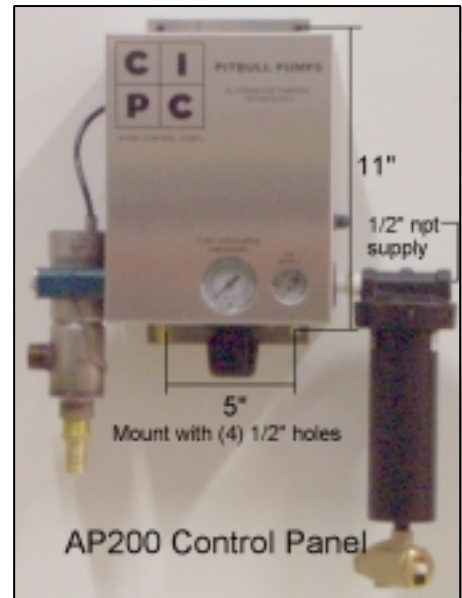

COMMONLY ASKED INSTALLATION/APPLICATION QUESTIONS

How much air will it actually use?

The PITBULL® matches your incoming flow rate. So when the inflow drops to half, the air consumption is cut in half too. Actual air consumption is usually much less than shown unless inflow is constant.

Can the airlines be hard-piped?

Yes they can, but the ID's of our standard lines must be matched.

Where is the control panel mounted?

Place within the 15' radius of the airlines, above the pump. Up to 20' extra lines can be ordered (consult CIPC if more is required).

Can the piping be reduced?

Smaller piping causes higher head and velocity, and the pump may pass things the piping can't. Try to avoid dropping more than one pipe size.