

# PITBULL® MODELS F3C & F3S SLUDGE AND FILTER-PRESS PUMPS

The model F3C (steel) and F3S(316SS) are 'variable head' transfer pumps designed *specifically* for sludge/slurry transfer and filter press feed. These types of applications usually require high maintenance for a variety of reasons; abrasion, varying discharge head caused by inconsistent solids content, wide ranges in back pressure as a plate and frame filter press fills up and just simply heavy usage. Centrifugal pumps are abused by the changing discharge pressures, solids content and abrasion, while diaphragm pumps can fail under the high cycle duty.

The PITBULL® has an extremely low cycle rate, eliminates seals, impellers and diaphragms, and the ability to hand a wide range of solids content and discharge pressures is inherent in the design. The PITBULL® can solve your maintenance headaches.

Each pump is supplied with the DP220 'filter press' control panel. The DP220 is an electropneumatic controller that automatically cycles the pump, slowing the rate as the backpressure climbs. They will not over-cycle under low heads and can be left to dead-head indefinitely on a full filter press **without stalling**.

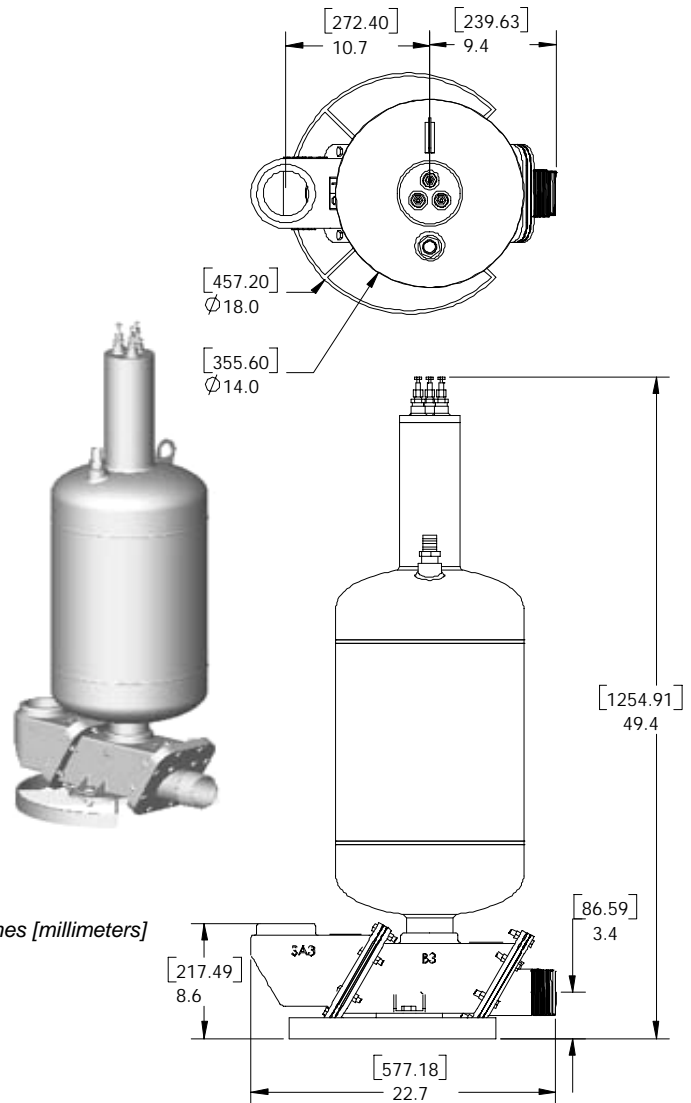

## SPECIFICATIONS

- } Weight: 143 lbs/65 kg
- } Piping: 3 inch NPT
- } Control panel: DP220 electropneumatic
- } Volume: 14 gal/53 liters
- } Maximum discharge head: 125 psi/8.6 Bar
- } Maximum solid: 3 inch/76mm diameter
- } Lowest flooded operating level
  - 30 inches/762 mm (above pump base)
- } Maximum suction lift (optional)
  - 15 feet/4.6m (@1.0 sg;
  - (see reverse side for details)

## REQUIREMENTS

- } Compressed air or dry gas, >40 psi/2.6 Bar
- } 1" NPT air supply inlet
- } 40 micron filtration recommended
- } 110 VAC power (<.2 amp)

## MAXIMUM FLOW CURVE

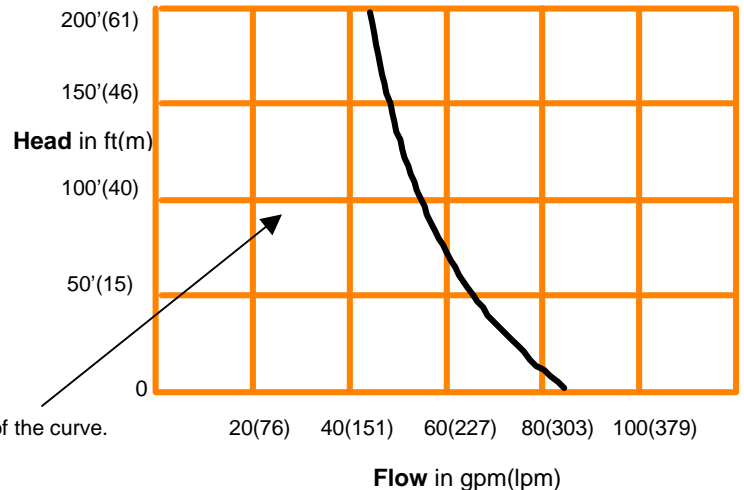

Pump can operate anywhere left of the curve.

Model and options selection:

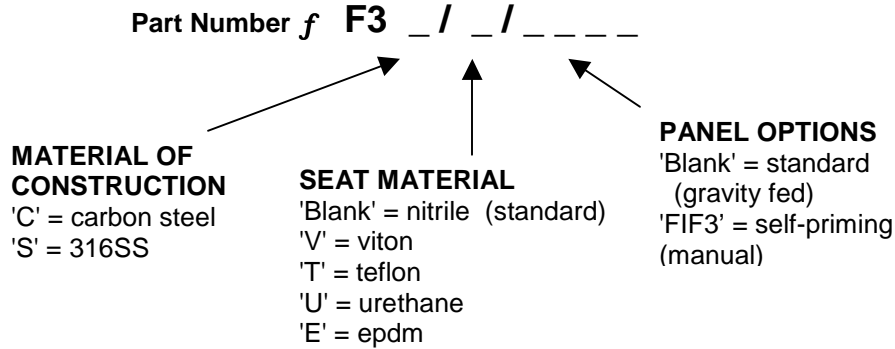

**Standard units:**

- #F3C = a steel 3" filter press pump with steel checks and nitrile seats.
- #F3S = a 316SS 3" filter press pump with 316SS checks and nitrile seats.

Custom unit example:

#F3C/E/FIF3 = a steel 3" filter press pump with steel checks, EPDM seats and self-priming option.

**A complete pump contains: pump, inlet and discharge check valves, an DP220 electropneumatic control panel and 15' of airline/probe cord.**

**Description of options:**

'FIF3' self priming. This is an air powered, vacuum generator along with a relief check valve, mounted to the exhaust valve of the control panel. It is operated by a manual ball valve: 'open' generates full suction lift, 'closed' the pump runs as a standard, gravity fed unit.

**Valve seat selection:**

- Nitrile - good all-purpose elastomer. Medium chemical, oil and solvent resistance, good strength, use to 170°F.
- Viton - excellent resistance to oxidizers and solvents. Medium strength, use to 250°F.
- Teflon - best chemical resistance of all. Inert to acids, bases and solvents. Lower cycle life, non-elastomeric, use to 300°F.
- Urethane - best resistance to abrasion. Toughest of the elastomers, with mild chemical resistance, use to 150°F.
- EPDM - good heat and acid/base resistance. Tougher than viton but poor solvent resistance, use to 300°F.

**SELF-PRIMING NOTES**

Flow rates are based upon 4' or less of suction lift. Deduct approximately 10% from the rated flow for each 1.5' of suction lift greater than 4'.  
On/Off of the self-priming is controlled by a ball valve. Air valves controlled by level controls or other inputs can be used.

**SELF-PRIMING AIR USAGE**

The air consumption chart is based upon gravity fed conditions. Using the self-priming option will increase air consumption 8 - 15 SCFM depending on the suction lift and flow required. Minimum pressure required to create suction lift is 50 psi, with maximum performance at 80 psi.

**AIR CONSUMPTION in SCFM**

Head Flow	10 ft	20 ft	40 ft	60 ft	80 ft	100 ft	140 ft	180 ft	220 ft
10 gpm	2	2.4	3.2	4.1	4.9	5.8	7.5	9.3	11
20 gpm	3.8	4.7	6.4	8.1	9.9	11.6	15.1	18.5	22
30 gpm	5.7	7	9.6	12.2	14.8	17.4	22.6	27.8	33
40 gpm	7.6	9.4	12.8	16.3	19.7	23.2	30.1	37.1	44
60 gpm	11.4	14	19.2	24.4	29.6	34.8	45.2	55.6	66
80 gpm	15.2	18.7	25.6	32.6	39.5	46.4	60.3	74.1	88
100 gpm	19	23.4	32	40.7	49.4	58	75.3	92.7	110
140 gpm	26.6	32.7	44.8	57	69.1	81.2	105.5	129.7	154

Example: 60 gpm @ 20 ft TDH requires 14 SCFM

**COMMONLY ASKED INSTALLATION/APPLICATION QUESTIONS**

**How is the pump controlled?** On-Off should be controlled by opening or closing the liquid supply. Without liquid the pump will not cycle (do not cut off the air supply - the pump will fill and not be able to pressurize)

**Can the flow rate be controlled?**

Yes, three different ways. 1) throttle the inflow to slow the cycle rate, 2) throttle the exhaust to slow the fill rate, 3) adjust the air pressure to control the discharge flow rate

**Can the piping be reduced?** Smaller piping causes higher head and velocity, and the pump may pass things the piping can't. Try to avoid dropping more than one pipe size.

**Should isolation valves be used before and after the pump?**

Absolutely

**How does the self priming work?**

By sucking air out of the pump, much like a vac truck, or vacuum cleaner. CIPC uses a venturi principle to create the vacuum, without any moving parts.